

Model: 3870ELC-D

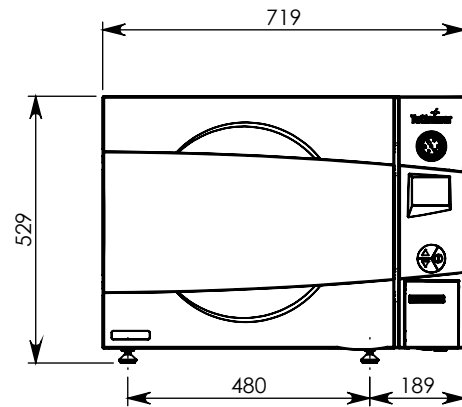

Front view

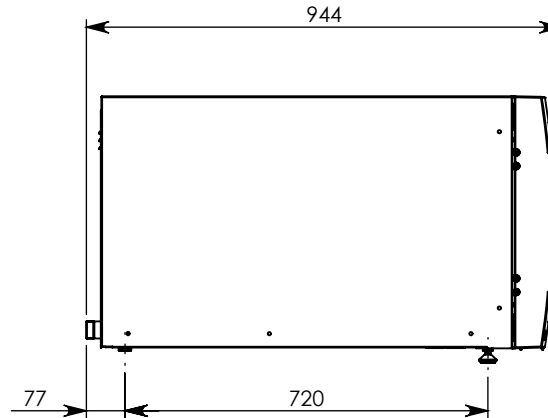

Left side view

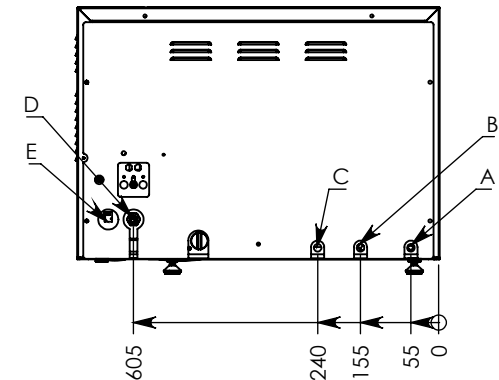

Back view

Model	Chamber diameter x depth	Volume
3870ELC-D	380x 700	85 Liter

Electrical options	Standard	Optional (additional cost)	Optional switch box from 3ph to 1 ph
Voltage	380V/400V	208V/230V	230 V
Electric Power	4.5kW	4.5kW	4.5kW
Amperage	7A	11A	21A
Phase	3 Ph	3 Ph	1 Ph

No.	Description	Size	Minimum Pressure
A	Air pressure inlet (C model only)	1/2" -Male	3 Bar
B	Tap water inlet (C model only)	1/2" - Male	2 Bar
C	Drain (C model only)	1/2" - Male	-
D	Power supply	-	-
E	Ethernet port	RJ-45	-

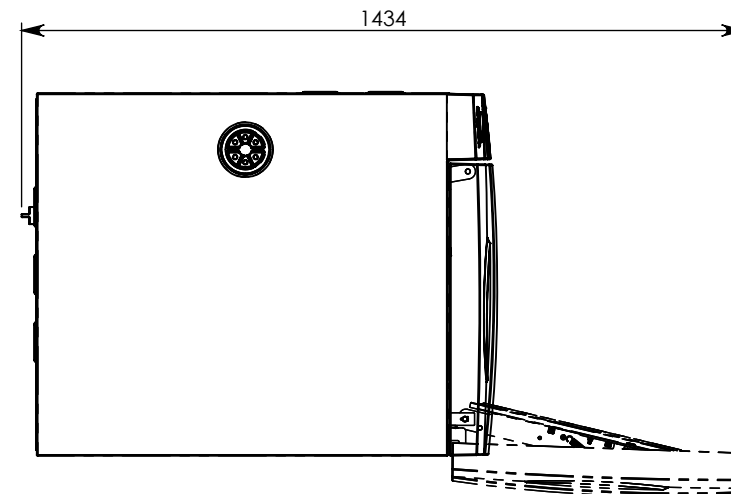

Top view

Installation drawing